

Fail Secure Sturdiness Electric Bolt With Cylinder

Model:EL-500C(LED)

Parameters

Face Plate	210Lx25Wx42H(mm)
Strike	90Lx25Wx3H(mm)
Bolt	16(projecture)*13(diameter)(mm)
Holding Force	1000Kg
Cylinder	one side is key, another side is knob(75mm)
Time Delay	0/3/6/9sec(Adjustable)
Voltage	12VDC(24VDC need order)
Current	Start 960mA,Standby 180mA
Signal Output	NO/COM
LED	Green indicates the door is unlock; Red indicates the door is lock
Material	304 stainless steel, wire draw finishing
Induction Distance	8mm
Feature	Fail secure(Fail safe need order)
Suitable for	Wooden door, metal door ,Fireproof door
Weight	1.0 kg

Dimensions

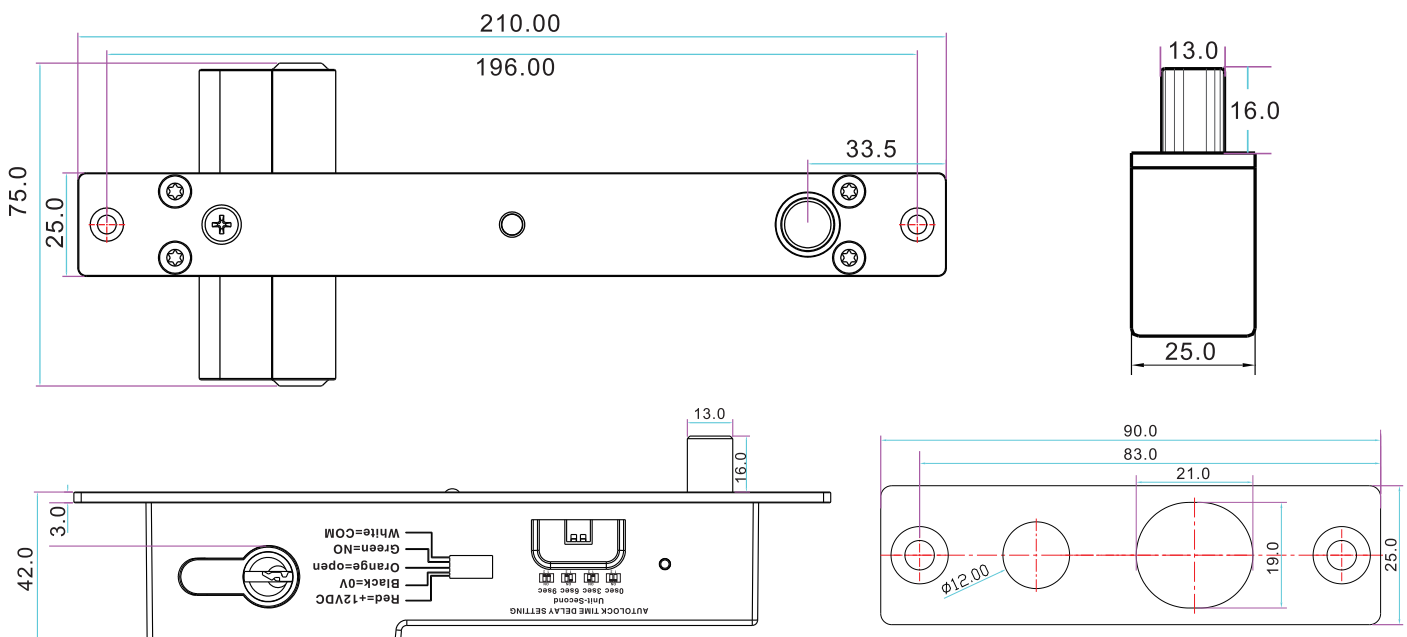

Installation

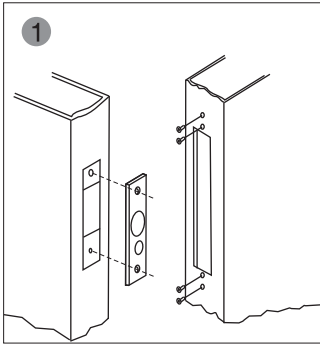

1 Mark the dimension of holes on the door leaf, cut the hole for the lock body and magnetic plate.

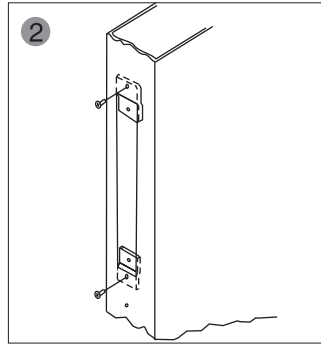

2 Install the fixing plug.

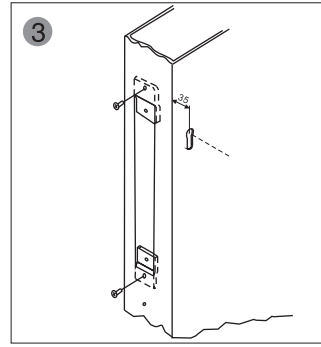

3 Cut the hole for the lock cylinder.

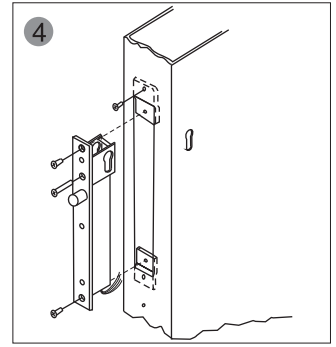

4 Connect the power.

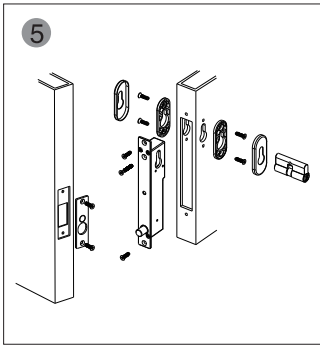

5 Fix the lock body, install the lock cylinder and cover plate

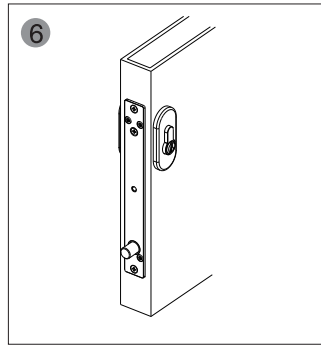

6 Fix the lock cylinder by the screw.

Wiring Diagram

